

Designers & Manufacturers of Drilling & Tapping Solutions

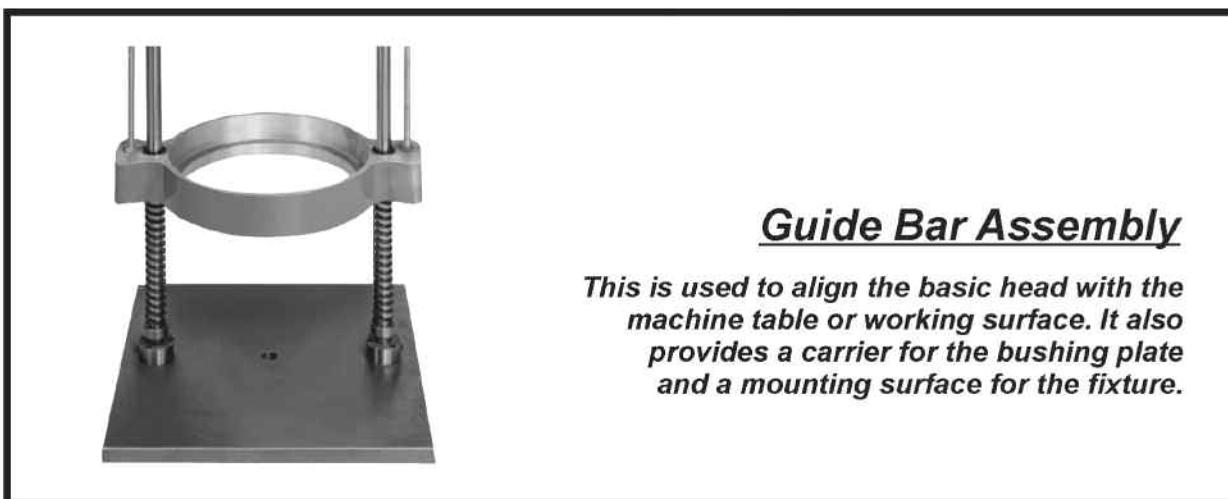

Guide Bar Assembly

This is used to align the basic head with the machine table or working surface. It also provides a carrier for the bushing plate and a mounting surface for the fixture.

Slip Plate

This is used to give a rigid, fixed position accuracy to the cartridge spindle positions, and reduce set-up time for repeat runs with the same pattern. It also allows the spindle and tooling arrangement to be left intact from set-up to set-up.



Posi-Quick Set-Up Plate

This is used to give a positive accurate location to the arm spindle positions, reduce set-up time, and provide support to the spindle arm.